

DENTAL 精密加工的优先选择—

# DENTAL SERIES

氧化锆加工用 金刚石涂层球头车针

设备类别 CAD/CAM Milling Bur

氧化锆加工用 深沟球头车针  
Rib Ball End Mills for Titanium & Cobalt-Chrom & Abutment



氧化锆加工用 金刚石涂层球头车针  
Diamond Coated Ball End Mills for Zirconia



氧化锆加工用 金刚石涂层球头车针  
Diamond Coated Ball End Mills for Zirconia



PMMA / PEEK / WAX 深沟球头车针  
Rib Ball End Mills for PMMA & PEEK & WAX



研磨金钢砂车针  
Electro Deposited Diamond End Mill

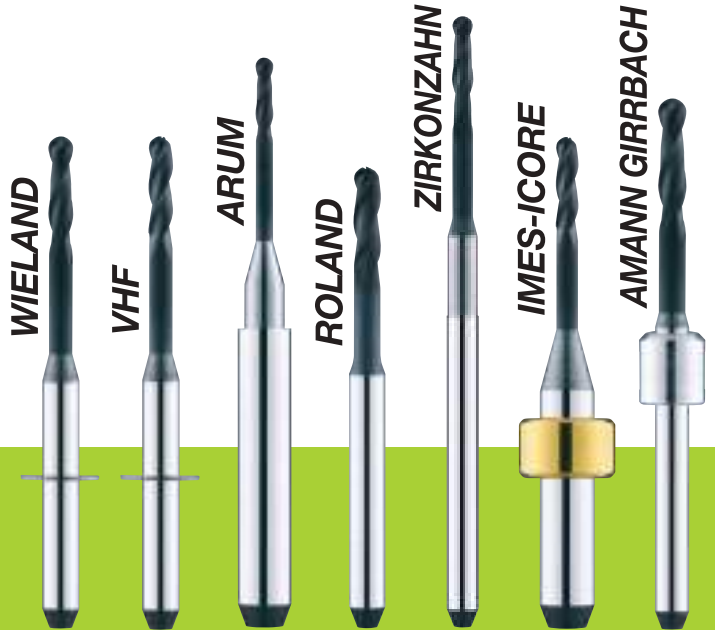

1 钴铬合金加工



2 氧化锆加工



2 氧化锆加工

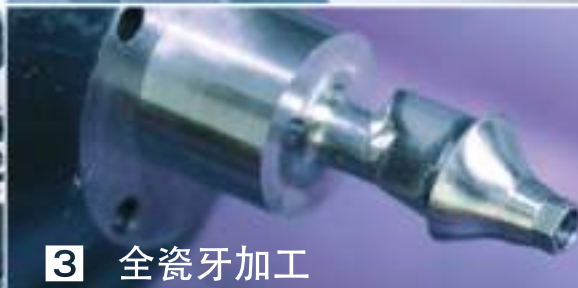

3 全瓷牙加工



4 基台加工



Outstanding Abrasion Resistance & Surface Finishes!  
**卓越的耐磨性 & 镜面效果!**

**DENTAL 精密加工的最佳选择—**

# DENTAL SERIES

## 2HRBD

2 Flutes High Speed Rib Ball End Mills for Titanium & Cobalt-Chrome

**钛/钴铬合金加工2刃高速球刀**

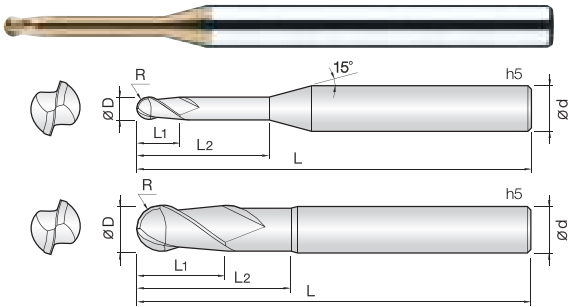

- 适用于精密加工钛/钴铬合金/基台系列的铣刀
- 采用了硅系列 (Si) 涂层处理, 具有优异的耐磨性。
- 采用高精度公差控制, 适用于高精加工。
- 精湛的刀刃设计, 切削出优质的光洁面。
- **Endmills for titanium and cobalt-chrome disk & abutment**
- Good wear resistance by Si-based PVD coating.
- High precise edge tolerance.
- Very nice work surface finish.

单位: mm

Order Number	刃径 Diameter R × D	刃长 Length of cut L1	有效长 Effective Length L2	全长 Overall Length L	柄径 Shank Dia d	备注	Order Number	刃径 Diameter R × D	刃长 Length of cut L1	有效长 Effective Length L2	全长 Overall Length L	柄径 Shank Dia d	备注
2HRBD 006 050 645	0.3R X 0.6	0.8	5	45	6		2HRBD 020 140 650	1R X 2	3	14	50	6	
2HRBD 006 050 650	0.3R X 0.6	0.8	5	50	6		2HRBD 020 160 645	1R X 2	3	16	45	6	
2HRBD 006 120 645	0.3R X 0.6	0.8	12	45	6		2HRBD 020 160 650	1R X 2	3	16	50	6	
2HRBD 006 120 650	0.3R X 0.6	0.8	12	50	6		2HRBD 030 080 645	1.5R X 3	4	8	45	6	
2HRBD 008 080 645	0.4R X 0.8	1	8	45	6		2HRBD 030 100 645	1.5R X 3	4	10	45	6	
2HRBD 008 080 650	0.4R X 0.8	1	8	50	6		2HRBD 030 120 645	1.5R X 3	4	12	45	6	
2HRBD 008 120 645	0.4R X 0.8	1	12	45	6		2HRBD 030 120 650	1.5R X 3	4	12	50	6	
2HRBD 008 120 650	0.4R X 0.8	1	12	50	6		2HRBD 030 160 645	1.5R X 3	4	16	45	6	
2HRBD 010 040 645	0.5R X 1	2	4	45	6		2HRBD 030 160 650	1.5R X 3	4	16	50	6	
2HRBD 010 060 645	0.5R X 1	2	6	45	6								
2HRBD 010 080 645	0.5R X 1	2	8	45	6								
2HRBD 010 080 650	0.5R X 1	2	8	50	6								
2HRBD 010 100 645	0.5R X 1	2	10	45	6								
2HRBD 010 100 650	0.5R X 1	2	10	50	6								
2HRBD 010 120 645	0.5R X 1	2	12	45	6								
2HRBD 010 120 650	0.5R X 1	2	12	50	6								
2HRBD 015 100 645	0.75R X 1.5	2.5	10	45	6								
2HRBD 015 120 645	0.75R X 1.5	2.5	12	45	6								
2HRBD 015 120 650	0.75R X 1.5	2.5	12	50	6								
2HRBD 015 140 645	0.75R X 1.5	2.5	14	45	6								
2HRBD 015 140 650	0.75R X 1.5	2.5	14	50	6								
2HRBD 020 050 645	1R X 2	3	5	45	6								
2HRBD 020 080 645	1R X 2	3	8	45	6								
2HRBD 020 120 645	1R X 2	3	12	45	6								
2HRBD 020 120 650	1R X 2	3	12	50	6								
2HRBD 020 140 645	1R X 2	3	14	45	6								

### 氧化锆加工2刃金刚石涂层球刀

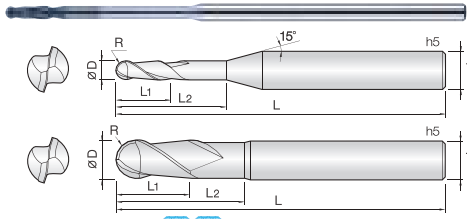

- 适用于加工氧化钙 (ZrO<sub>2</sub>)、绝缘材料等非铁、非金属系列的多种材料
- 采用NANO金刚石涂层 (CVD), 可以实现高光洁度, 高耐磨性等特点。
- 具有多种规格的刀具产品, 应用于广泛的领域, 演绎卓越的加工效果。
- **Endmills for Zirconia, Ultimate, Non-ferrous and non-metallic materials.**
- Excellent wear resistance and surface finishes by applying qualified CVD diamond coating.
- Wide range products prepared for various work shape and excellent performance.

单位: mm

Order Number	刃径 Diameter R × D	刃长 Length of cut L1	有效长 Effective Length L2	全长 Overall Length L	柄径 Shank Dia d	备注
2DBED 005 050 345	0.25R X 0.5	1.5	5	45	3	
2DBED 005 050 350	0.25R X 0.5	1.5	5	50	3	
2DBED 005 050 445	0.25R X 0.5	1.5	5	45	4	
2DBED 005 050 450	0.25R X 0.5	1.5	5	50	4	
2DBED 005 050 645	0.25R X 0.5	1.5	5	45	6	
2DBED 005 050 650	0.25R X 0.5	1.5	5	50	6	
2DBED 005 120 345	0.25R X 0.5	1.5	12	45	3	
2DBED 005 120 350	0.25R X 0.5	1.5	12	50	3	
2DBED 005 120 445	0.25R X 0.5	1.5	12	45	4	
2DBED 005 120 450	0.25R X 0.5	1.5	12	50	4	
2DBED 005 120 645	0.25R X 0.5	1.5	12	45	6	
2DBED 005 120 650	0.25R X 0.5	1.5	12	50	6	
2DBED 006 050 345	0.3R X 0.6	2	5	45	3	
2DBED 006 050 350	0.3R X 0.6	2	5	50	3	
2DBED 006 050 445	0.3R X 0.6	2	5	45	4	
2DBED 006 050 450	0.3R X 0.6	2	5	50	4	
2DBED 006 050 645	0.3R X 0.6	2	5	45	6	
2DBED 006 050 650	0.3R X 0.6	2	5	50	6	
2DBED 006 120 345	0.3R X 0.6	2	12	45	3	
2DBED 006 120 350	0.3R X 0.6	2	12	50	3	
2DBED 006 120 445	0.3R X 0.6	2	12	45	4	
2DBED 006 120 450	0.3R X 0.6	2	12	50	4	
2DBED 006 120 645	0.3R X 0.6	2	12	45	6	
2DBED 006 120 650	0.3R X 0.6	2	12	50	6	
2DBED 010 160 350	0.5R X 1	6	16	50	3	
2DBED 010 160 355	0.5R X 1	6	16	55	3	
2DBED 010 160 450	0.5R X 1	6	16	50	4	
2DBED 010 160 455	0.5R X 1	6	16	55	4	
2DBED 010 160 650	0.5R X 1	6	16	50	6	
2DBED 010 160 655	0.5R X 1	6	16	55	6	
2DBED 010 180 350	0.5R X 1	6	18	50	3	
2DBED 010 180 355	0.5R X 1	6	18	55	3	
2DBED 010 180 450	0.5R X 1	6	18	50	4	
2DBED 010 180 455	0.5R X 1	6	18	55	4	
2DBED 010 180 650	0.5R X 1	6	18	50	6	
2DBED 010 180 655	0.5R X 1	6	18	55	6	
2DBED 020 160 350	1R X 2	8	16	50	3	
2DBED 020 160 355	1R X 2	8	16	55	3	
2DBED 020 160 450	1R X 2	8	16	50	4	
2DBED 020 160 455	1R X 2	8	16	55	4	
2DBED 020 160 650	1R X 2	8	16	50	6	
2DBED 020 160 655	1R X 2	8	16	55	6	
2DBED 020 200 350	1R X 2	8	20	50	3	
2DBED 020 200 355	1R X 2	8	20	55	3	
2DBED 020 200 450	1R X 2	8	20	50	4	
2DBED 020 200 455	1R X 2	8	20	55	4	
2DBED 020 200 650	1R X 2	8	20	50	6	
2DBED 020 200 655	1R X 2	8	20	55	6	
2DBED 030 200 355	1.5R X 3	10	20	55	3	
2DBED 030 200 455	1.5R X 3	10	20	55	4	
2DBED 030 200 655	1.5R X 3	10	20	55	6	

## 亚克力/聚醚醚酮/蜡加工2刃球刀

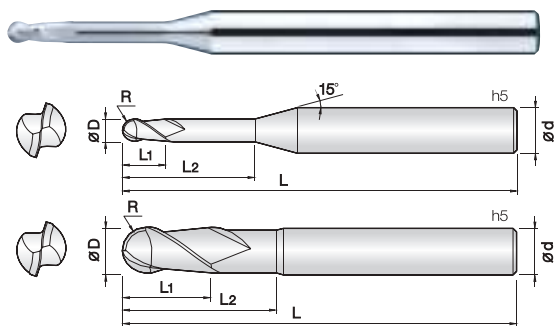

- 亚克力/聚醚醚酮/蜡等非铁、非金属加工铣刀
- 对刃距的高精度公差控制，减少了切削振动。
- 对短刃的精湛设计，在大给进高速加工时，显示出其坚固的优势。
- 采用强刃线的硬度的设计，极大地降低了刃部崩刃现象。
- 由于采用了超微粒子超硬合金，具有优异的耐磨性。
- Endmills for PMMA, PEEK, WAX, A.B.S, non-ferrous and non-metallic materials.
- Minimize chattering by even run-out and tolerance control.
- Excellent tool rigidity by short flute design at high speed, feed machining.
- Reinforced edge design for preventing edge chipping.
- Excellent wear resistance by applying fine WC grade.

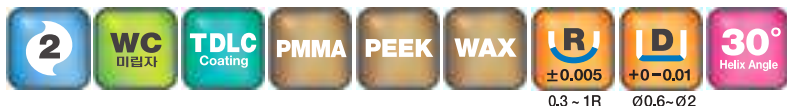

单位：mm

Order Number		刃径 Diameter R×D	刃长 Length of cut L1	有效长 Effective Length L2	全长 Overall Length L	柄径 Shank Dia d	备注	
非涂层 Non coated	涂层 Coated						非涂层 Non coated	涂层 Coated
2MRBD 006 050 450	2MRBDD 006 050 450	0.3R X 0.6	2	5	50	4		
2MRBD 006 050 650	2MRBDD 006 050 650	0.3R X 0.6	2	5	50	6		
2MRBD 006 100 450	2MRBDD 006 100 450	0.3R X 0.6	2	10	50	4		
2MRBD 006 100 650	2MRBDD 006 100 650	0.3R X 0.6	2	10	50	6		
2MRBD 010 140 455	2MRBDD 010 140 455	0.5R X 1	6	14	55	4		
2MRBD 010 140 655	2MRBDD 010 140 655	0.5R X 1	6	14	55	6		
2MRBD 010 160 455	2MRBDD 010 160 455	0.5R X 1	6	16	55	4		
2MRBD 010 160 655	2MRBDD 010 160 655	0.5R X 1	6	16	55	6		
2MRBD 020 160 455	2MRBDD 020 160 455	1R X 2	8	16	55	4		
2MRBD 020 160 655	2MRBDD 020 160 655	1R X 2	8	16	55	6		
2MRBD 020 200 455	2MRBDD 020 200 455	1R X 2	8	20	55	4		
2MRBD 020 200 655	2MRBDD 020 200 655	1R X 2	8	20	55	6		

## 研磨金钢砂车针

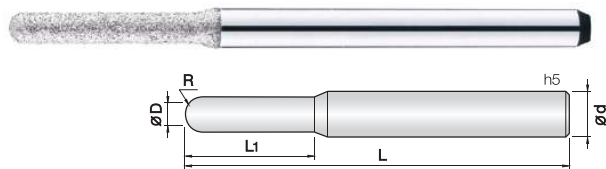

- 适用于氧化锆、全瓷牙非金属系列的多种材料。
- 对比金刚石车针大幅减少了崩齿现象。
- 减少了被加工材料的崩损。
- Endmills for Zirconia, E-MAX, Ultimate, Non-ferrous and non-metallic materials.
- Minimized brittle fracture by intermittent cutting.



单位：mm

Order Number	刃径 Diameter R×D	刃长 Length of cut L1	全长 Overall Length L	柄径 Shank Dia d	备注
EDD 006 060 340	0.3R X 0.6	6	40	3	
EDD 006 060 348	0.3R X 0.6	6	48	3	
EDD 006 060 440	0.3R X 0.6	6	40	4	
EDD 006 060 450	0.3R X 0.6	6	50	4	
EDD 006 060 640	0.3R X 0.6	6	40	6	
EDD 006 060 650	0.3R X 0.6	6	50	6	
EDD 010 100 340	0.5R X 1	10	40	3	
EDD 010 100 348	0.5R X 1	10	48	3	
EDD 010 100 440	0.5R X 1	10	40	4	
EDD 010 100 450	0.5R X 1	10	50	4	
EDD 010 100 640	0.5R X 1	10	40	6	
EDD 010 100 650	0.5R X 1	10	50	6	
EDD 015 080 450	0.75R X 1.5	8	50	4	

Order Number	刃径 Diameter R×D	刃长 Length of cut L1	全长 Overall Length L	柄径 Shank Dia d	备注
EDD 020 120 340	1R X 2	12	40	3	
EDD 020 120 348	1R X 2	12	48	3	
EDD 020 120 440	1R X 2	12	40	4	
EDD 020 120 450	1R X 2	12	50	4	
EDD 020 120 640	1R X 2	12	40	6	
EDD 020 120 650	1R X 2	12	50	6	
EDD 025 150 340	1.25R X 2.5	15	40	3	
EDD 025 150 348	1.25R X 2.5	15	48	3	
EDD 025 150 440	1.25R X 2.5	15	40	4	
EDD 025 150 450	1.25R X 2.5	15	50	4	
EDD 025 150 640	1.25R X 2.5	15	40	6	
EDD 025 150 650	1.25R X 2.5	15	50	6	





## 1刃 PMMA/PEEK/WAX 深沟球头车针 1 Flutes Rib Ball End Mills for PMMA & PEEK & WAX

互换设备 (Compatible Machine)  
DWX 50, DWX 30, DWX 51D

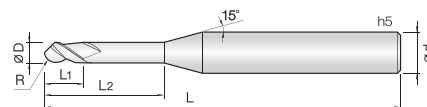

- 适用于树脂(PMMA),PEEK,WAX,A.B.S等非金属加工
- Endmills for PMMA, PEEK, WAX, A.B.S, non-ferrous and non-metallic materials.

单位: mm

Order Number	刃径 Diameter R×D	刃长 Length of cut L1	有效长 Effective Length L2	总长 Overall Length L	柄径 Shank Dia d	备注
1ROL 006 060 S04	0.3R X 0.6	2	6	50	4	
1ROL 006 140 S04	0.3R X 0.6	2	14	50	4	
1ROL 010 160 S04	0.5R X 1	6	16	50	4	
1ROL 010 200 S04	0.5R X 1	6	20	50	4	
1ROL 020 200 S04	1R X 2	8	20	50	4	
1ROL 030 200 S04	1.5R X 3	10	20	50	4	



## 2&3刃 氧化锆加工用 金刚石涂层球头车针 2&3 Flutes Diamond Coated Ball End Mills for Zirconia

互换设备 (Compatible Machine)  
DWX 50, DWX 30, DWX 51D

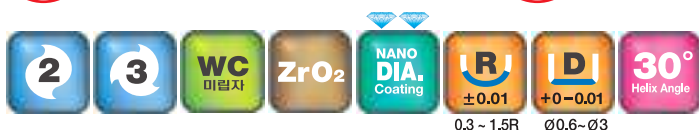
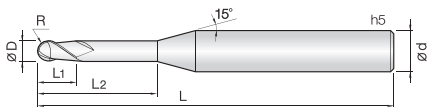
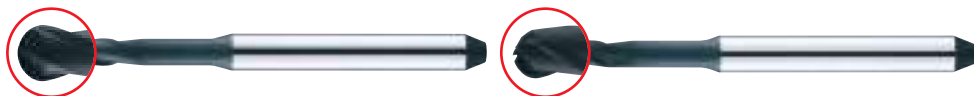

- 适用于氧化锆、全瓷牙非金属系列的多种材料
- Endmills for Zirconia, Ultimate, Non-ferrous and non-metallic materials.

单位: mm

Order Number	刃径 Diameter R×D	刃长 Length of cut L1	有效长 Effective Length L2	总长 Overall Length L	柄径 Shank Dia d	备注
2ROL 006 060 S04	0.3R X 0.6	2	6	50	4	
2ROL 006 140 S04	0.3R X 0.6	2	14	50	4	
2ROL 010 160 S04	3ROL 010 160 S04	0.5R X 1	6	16	50	4
2ROL 010 200 S04	3ROL 010 200 S04	0.5R X 1	6	20	50	4
2ROL 020 200 S04	3ROL 020 200 S04	1R X 2	8	20	50	4
2ROL 030 200 S04	3ROL 030 200 S04	1.5R X 3	10	20	50	4

**1VHF** 1刃 PMMA/PEEK/WAX 深沟球头车针  
1 Flutes Rib Ball End Mills for PMMA & PEEK & WAX

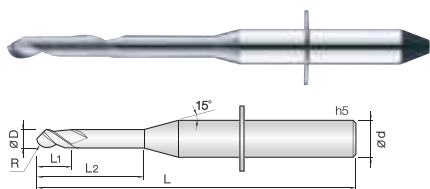

- 适用于树脂(PMMA),PEEK,WAX,A.B.S等非金属加工
- Endmills for PMMA, PEEK, WAX, A.B.S, non-ferrous and non-metallic materials

单位: mm

Order Number	刃径 Diameter R×D	刃长 Length of cut L1	有效长 Effective Length L2	全长 Overall Length L	柄径 Shank Dia d	备注
1VHF 006 070 S03	0.3R X 0.6	2	7	35	3	
1VHF 006 110 S03	0.3R X 0.6	2	11	35	3	
1VHF 010 160 S03	0.5R X 1	5	16	35	3	
1VHF 020 170 S03	1R X 2	8	17	35	3	

**2&3VHF** 2&3刃 氧化锆加工用 深沟球头车针  
2&3 Flutes Rib Ball End Mills for Zirconia

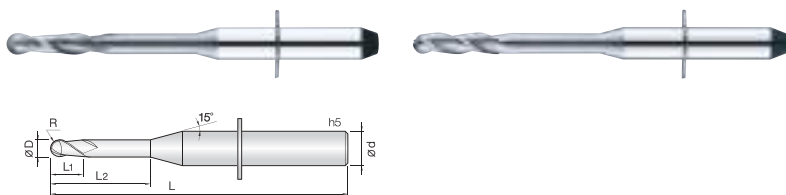

- 适用于氧化锆、全瓷牙非金属系列的多种材料
- Endmills for Zirconia, Ultimate, Non-ferrous and non-metallic materials.

单位: mm

Order Number	刃径 Diameter R×D	刃长 Length of cut L1	有效长 Effective Length L2	全长 Overall Length L	柄径 Shank Dia d	备注
2VHF 006 070 S03	0.3R X 0.6	2	7	35	3	
2VHF 006 110 S03	0.3R X 0.6	2	11	35	3	
2VHF 010 160 S03	3VHF 010 160 S03 0.5R X 1	5	16	35	3	
2VHF 020 170 S03	3VHF 020 170 S03 1R X 2	8	17	35	3	

**2&3VHFD** 2&3刃 氧化锆加工用 金刚石涂层球头车针  
2&3 Flutes Diamond Coated Ball End Mills for Zirconia

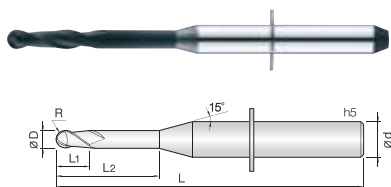

- 适用于氧化锆、全瓷牙非金属系列的多种材料
- Endmills for Zirconia, Ultimate, Non-ferrous and non-metallic materials.

单位: mm

Order Number	刃径 Diameter R×D	刃长 Length of cut L1	有效长 Effective Length L2	全长 Overall Length L	柄径 Shank Dia d	备注
2VHFD 006 070 S03	0.3R X 0.6	2	7	40	3	
2VHFD 006 110 S03	0.3R X 0.6	2	11	40	3	
2VHFD 010 170 S03	3VHFD 010 170 S03 0.5R X 1	5	17	40	3	
2VHFD 020 170 S03	3VHFD 020 170 S03 1R X 2	8	17	40	3	



1刃 PMMA/PEEK/WAX 深沟球头车针

1 Flutes Rib Ball End Mills for PMMA & PEEK & WAX

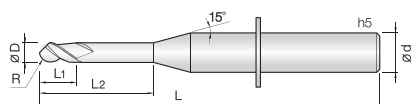

- 适用于树脂(PMMA),PEEK,WAX,A.B.S等非金属加工
- Endmills for PMMA, PEEK, WAX, A.B.S, non-ferrous and non-metallic materials

单位: mm

Order Number	刃径 Diameter R×D	刃长 Length of cut L1	有效长 Effective Length L2	全长 Overall Length L	柄径 Shank Dia d	备注
1WIE 006 070 335	0.3R X 0.6	2	7	35	3	
1WIE 006 070 340	0.3R X 0.6	2	7	40	3	
1WIE 007 070 335	0.35R X 0.7	2	7	35	3	
1WIE 007 070 340	0.35R X 0.7	2	7	40	3	
1WIE 010 160 335	0.5R X 1	5	16	35	3	
1WIE 010 170 340	0.5R X 1	5	17	40	3	
1WIE 020 170 335	1R X 2	8	17	35	3	
1WIE 020 170 340	1R X 2	8	17	40	3	
1WIE 025 200 335	1.25R X 2.5	10	20	35	3	
1WIE 025 200 340	1.25R X 2.5	10	20	40	3	



2&3刃 氧化锆加工用 深沟球头车针

2&3 Flutes Rib Ball End Mills for Zirconia

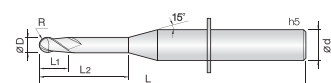

- 适用于氧化锆、全瓷牙非金属系列的多种材料
- Endmills for Zirconia, Ultimate, Non-ferrous and non-metallic materials.

单位: mm

Order Number	刃径 Diameter R×D	刃长 Length of cut L1	有效长 Effective Length L2	全长 Overall Length L	柄径 Shank Dia d	备注
2WIE 006 070 335	0.3R X 0.6	2	7	35	3	
2WIE 007 070 335	0.35R X 0.7	2	7	35	3	
2WIE 010 160 335	3WIE 010 160 335	0.5R X 1	5	16	3	
2WIE 020 170 335	3WIE 020 170 335	1R X 2	8	17	3	
2WIE 025 200 335	3WIE 025 200 335	1.25R X 2.5	10	20	3	



2&3刃 氧化锆加工用 金刚石涂层球头车针

2&3 Flutes Diamond Coated Ball End Mills for Zirconia

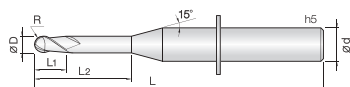

- 适用于氧化锆、全瓷牙非金属系列的多种材料
- Endmills for Zirconia, Ultimate, Non-ferrous and non-metallic materials.

单位: mm

Order Number	刃径 Diameter R×D	刃长 Length of cut L1	有效长 Effective Length L2	全长 Overall Length L	柄径 Shank Dia d	备注
2WIED 006 070 340	0.3R X 0.6	2	7	40	3	
2WIED 007 070 340	0.35R X 0.7	2	7	40	3	
2WIED 010 170 340	3WIED 010 170 340	0.5R X 1	5	17	3	
2WIED 020 170 340	3WIED 020 170 340	1R X 2	8	17	3	
2WIED 025 200 340	3WIED 025 200 340	1.25R X 2.5	10	20	3	



1刃 PMMA/PEEK/WAX 深沟球头车针  
1 Flutes Rib Ball End Mills for PMMA & PEEK & WAX

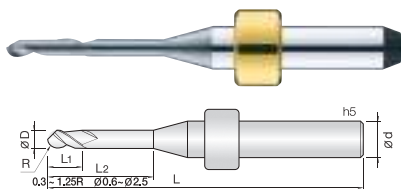

- 适用于树脂(PMMA),PEEK,WAX,A.B.S等非金属加工
- Endmills for PMMA, PEEK, WAX, A.B.S, non-ferrous and non-metallic materials

单位: mm

Order Number	刃径 Diameter R×D	刃长 Length of cut L1	有效长 Effective Length L2	全长 Overall Length L	柄径 Shank Dia d	备注
1IME 006 070 S03	0.3R X 0.6	2	7	48	3	
1IME 006 070 S06	0.3R X 0.6	2	7	53	6	
1IME 010 160 S03	0.5R X 1	2	16	48	3	
1IME 010 160 S06	0.5R X 1	2	16	53	6	
1IME 020 200 S03	1R X 2	8	20	48	3	
1IME 020 200 S06	1R X 2	8	20	53	6	
1IME 025 200 S03	1.25R X 2.5	9	20	48	3	
1IME 025 200 S06	1.25R X 2.5	9	20	53	6	



2&3刃 氧化锆加工用 金刚石涂层球头车针  
2&3 Flutes Diamond Coated Ball End Mills for Zirconia

2&3 Flutes Diamond Coated Ball End Mills for Zirconia

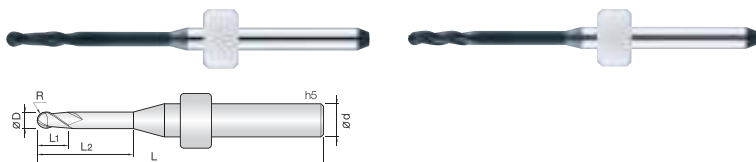

- 适用于氧化锆、全瓷牙非金属系列的多种材料
- Endmills for Zirconia, Ultimate, Non-ferrous and non-metallic materials.

单位: mm

Order Number	刃径 Diameter R×D	刃长 Length of cut L1	有效长 Effective Length L2	全长 Overall Length L	柄径 Shank Dia d	备注
2IME 006 070 S03	0.3R X 0.6	2	7	48	3	
2IME 010 160 S03	3IME 010 160 S03	0.5R X 1	2	16	48	3
2IME 020 200 S03	3IME 020 200 S03	1R X 2	8	20	48	3
2IME 025 200 S03	3IME 025 200 S03	1.25R X 2.5	9	20	48	3



2&3刃 氧化锆加工用 金刚石涂层球头车针  
2&3 Flutes Diamond Coated Ball End Mills for Zirconia

2&3 Flutes Diamond Coated Ball End Mills for Zirconia

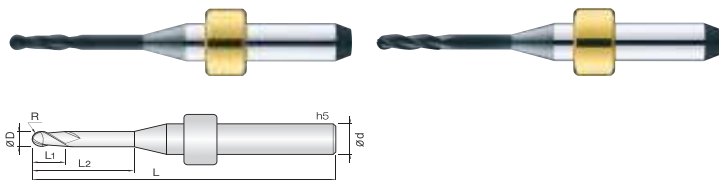

- 适用于氧化锆、全瓷牙非金属系列的多种材料
- Endmills for Zirconia, Ultimate, Non-ferrous and non-metallic materials.

单位: mm

Order Number	刃径 Diameter R×D	刃长 Length of cut L1	有效长 Effective Length L2	全长 Overall Length L	柄径 Shank Dia d	备注
2IME 006 070 S06	0.3R X 0.6	2	7	53	6	
2IME 010 160 S06	3IME 010 160 S06	0.5R X 1	2	16	53	6
2IME 020 200 S06	3IME 020 200 S06	1R X 2	8	20	53	6
2IME 025 200 S06	3IME 025 200 S06	1.25R X 2.5	9	20	53	6



**1ARU** 1刃 PMMA/PEEK/WAX 深沟球头车针  
1 Flutes Rib Ball End Mills for PMMA & PEEK & WAX

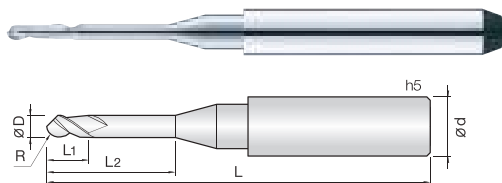

- 适用于树脂(PMMA),PEEK,WAX,A.B.S等非金属加工
- Endmills for PMMA, PEEK, WAX, A.B.S, non-ferrous and non-metallic materials

单位: mm

Order Number	刃径 Diameter R×D	刃长 Length of cut L1	有效长 Effective Length L2	全长 Overall Length L	柄径 Shank Dia d	备注
1ARU 006 130 050	0.3R X 0.6	2	13	50	6	
1ARU 006 130 063	0.3R X 0.6	2	13	63	6	
1ARU 010 160 053	0.5R X 1	6	16	53	6	
1ARU 010 160 063	0.5R X 1	6	16	63	6	
1ARU 020 200 055	1R X 2	8	20	55	6	
1ARU 020 200 063	1R X 2	8	20	63	6	

**2&3ARU** 2&3刃 氧化锆加工用 金刚石涂层球头车针  
2&3 Flutes Diamond Coated Ball End Mills for Zirconia

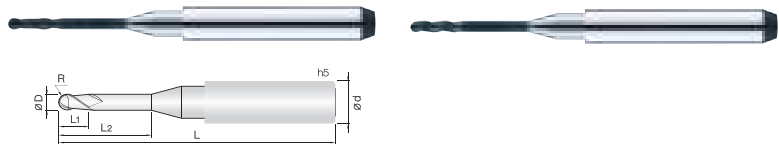

- 适用于氧化锆、全瓷牙非金属系列的多种材料
- Endmills for Zirconia, Ultimate, Non-ferrous and non-metallic materials.

单位: mm

Order Number	刃径 Diameter R×D	刃长 Length of cut L1	有效长 Effective Length L2	全长 Overall Length L	柄径 Shank Dia d	备注
2ARU 006 130 050	0.3R X 0.6	2	13	50	6	
2ARU 006 130 063	0.3R X 0.6	2	13	63	6	
2ARU 010 160 053	3ARU 010 160 053	0.5R X 1	6	16	53	6
2ARU 010 160 063	3ARU 010 160 063	0.5R X 1	6	16	63	6
2ARU 020 200 055	3ARU 020 200 055	1R X 2	8	20	55	6
2ARU 020 200 063	3ARU 020 200 063	1R X 2	8	20	63	6

**2ARUT** 2&3刃 氧化锆加工用 深沟球头车针  
2&3 Flutes Rib Ball End Mills for Titanium & Cobalt-Chrome

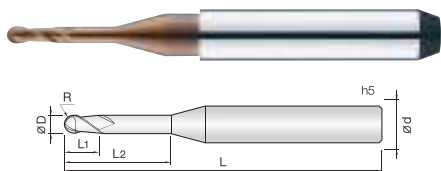

- 适用于氧化锆、全瓷牙非金属系列的多种材料
- Endmills for titanium and cobalt-chrom disk & abutment

单位: mm

Order Number	刃径 Diameter R×D	刃长 Length of cut L1	有效长 Effective Length L2	全长 Overall Length L	柄径 Shank Dia d	备注
2ARUT 010 080 S06	0.5R X 1	2	8	50	6	
2ARUT 015 100 S06	0.75R X 1.5	3	10	50	6	
2ARUT 020 120 S06	1R X 2	6	12	50	6	
2ARUT 030 120 S06	1.5R X 3	8	12	50	6	



## 1刃 PMMA/PEEK/WAX 深沟球头车针

1 Flutes Rib Ball End Mills for PMMA & PEEK & WAX

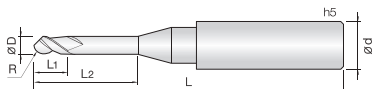

- 适用于树脂(PMMA),PEEK,WAX,A.B.S等非金属加工
- Endmills for PMMA, PEEK, WAX, A.B.S, non-ferrous and non-metallic materials

单位: mm

Order Number	刃径 Diameter R×D	刃长 Length of cut L1	有效长 Effective Length L2	全长 Overall Length L	柄径 Shank Dia d	备注
1ZIR 005 050 S03	0.25R X 0.5	3	5	57	3	
1ZIR 005 050 S06	0.25R X 0.5	3	5	50	6	
1ZIR 010 160 S03	0.5R X 1	8	16	57	3	
1ZIR 010 160 S06	0.5R X 1	8	16	50	6	
1ZIR 020 180 S03	1R X 2	10	18	57	3	
1ZIR 020 180 S06	1R X 2	10	18	50	6	



## 2&3刃 氧化锆加工用 深沟球头车针

2&3 Flutes Rib Ball End Mills for Zirconia

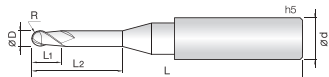

- 适用于氧化锆、全瓷牙非金属系列的多种材料
- Endmills for Zirconia, Ultimate, Non-ferrous and nonmetallic materials .

单位: mm

Order Number	刃径 Diameter R×D	刃长 Length of cut L1	有效长 Effective Length L2	全长 Overall Length L	柄径 Shank Dia d	备注
2ZIR 005 050 S03	0.25R X 0.5	3	5	57	3	
2ZIR 005 050 S06	0.25R X 0.5	3	5	50	6	
2ZIR 010 160 S03	3ZIR 010 160 S03	0.5R X 1	8	57	3	
2ZIR 010 160 S06	3ZIR 010 160 S06	0.5R X 1	8	50	6	
2ZIR 020 180 S03	3ZIR 020 180 S03	1R X 2	10	57	3	
2ZIR 020 180 S06	3ZIR 020 180 S06	1R X 2	10	50	6	



## 2&3刃 氧化锆加工用 金刚石涂层球头车针

2&3 Flutes Diamond Coated Ball End Mills for Zirconia

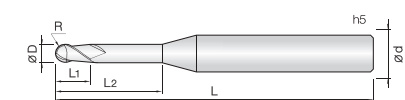

- 适用于氧化锆、全瓷牙非金属系列的多种材料
- Endmills for Zirconia, Ultimate, Non-ferrous and non-metallic materials.

单位: mm

Order Number	刃径 Diameter R×D	刃长 Length of cut L1	有效长 Effective Length L2	全长 Overall Length L	柄径 Shank Dia d	备注
2ZIRD 005 050 S03	0.25R X 0.5	3	5	57	3	
2ZIRD 005 050 S06	0.25R X 0.5	3	5	50	6	
2ZIR D010 160 S03	3ZIR D010 160 S03	0.5R X 1	8	57	3	
2ZIR D010 160 S06	3ZIR D010 160 S06	0.5R X 1	8	50	6	
2ZIR D020 180 S03	3ZIR D020 180 S03	1R X 2	10	57	3	
2ZIR D020 180 S06	3ZIR D020 180 S06	1R X 2	10	50	6	

**2ZIRT** 2刃钛钴铬合金 基台加工用深沟球头车针  
2 Flutes Rib Ball End Mills for Titanium & Cobalt-Chrome

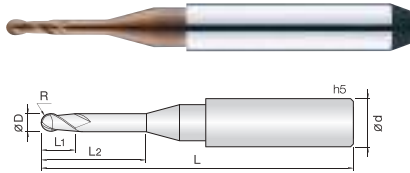

- 适用于钛钴铬合金和基台加工
- Endmills for titanium and cobalt-chrom disk & abutment

单位: mm

Order Number	刃径 Diameter R×D	刃长 Length of cut L1	有效长 Effective Length L2	全长 Overall Length L	柄径 Shank Dia d	备注
2ZIRT 020 180 S06	1R X 2	3	18	50	6	
2ZIRT 030 180 S06	1.5R X 3	4	18	50	6	

**1AMA** 1刃深沟球头车针  
1 Flutes Rib Ball End Mills for PMMA & PEEK & WAX

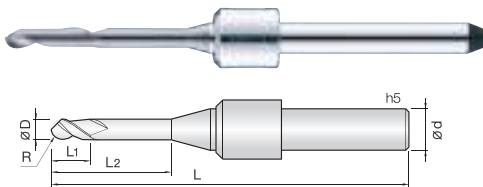

- 适用于树脂(PMMA),PEEK,WAX,A.B.S等非金属加工
- Endmills for PMMA, PEEK, WAX, A.B.S, non-ferrous and non-metallic materials.

单位: mm

Order Number	刃径 Diameter R×D	刃长 Length of cut L1	有效长 Effective Length L2	全长 Overall Length L	柄径 Shank Dia d	备注
1AMA 006 070 S03	0,3R X 0,6	2	7	47	3	
1AMA 010 170 S03	0,5R X 1	6	17	47	3	
1AMA 025 170 S03	1,25R X 2,5	9	17	47	3	

**2&3AMA** 2&3刃氧化锆加工用 金刚石涂层球头车针  
2&3 Flutes Diamond Coated Ball End Mills for Zirconia

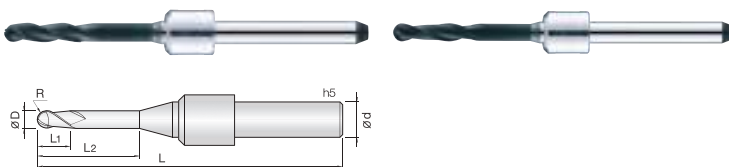

- 适用于氧化锆、全瓷牙非金属系列的多种材料
- Endmills for Zirconia, Ultimate, Non-ferrous and non-metallic materials.

单位: mm

Order Number	刃径 Diameter R×D	刃长 Length of cut L1	有效长 Effective Length L2	全长 Overall Length L	柄径 Shank Dia d	备注
2AMA 006 070 S03	0.3R X 0.6	2	7	47	3	
2AMA 010 170 S03	3AMA 010 170 S03 0.5R X 1	6	17	47	3	
2AMA 025 170 S03	3AMA 025 170 S03 1.25R X 2.5	9	17	47	3	

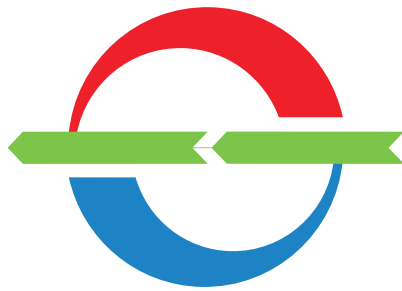

**您的非标品会是我们的标准品。**

韩国·首尔

330-16, Docksan-1dong, Guemcheon-gu,  
Seoul, 153-010, Korea Tel. +82.2.808.2745  
Fax. +82.2.808.2746

中国·上海

Tel. 021.6405.1112 Fax. 021.6405.2752



ISO 9001



ISO 14001

韩国匠精工具均获得国际品质标准  
ISO品质经营认证和环境标准认证。